



# Bi-directional 60 GHz Radio-on-Fiber Systems using Cascaded SOA-EAM Frequency Up/Down-converters

Jun-Hyuk Seo<sup>1</sup>, Chang-Soon Choi<sup>1</sup>, Young-Shik Kang<sup>2</sup>, Yong-Duck Chung<sup>2</sup>,  
Jeha Kim<sup>2</sup>, and Woo-Young Choi<sup>1</sup>

1. Department of Electrical and Electronic Engineering, Yonsei University, Seoul, 120-749, Korea
2. Electronics and Telecommunications Research Institute, Daejeon 305-350, Korea

**Abstract** — We demonstrate a bi-directional 60 GHz radio-on-fiber system using a novel frequency up/down-converter based on cascaded SOA-EAM configuration. SOA cross-gain modulation and photo-detection in EAM are used for frequency up-conversion and EAM nonlinearity is used for frequency down-conversion. Both optical LO and optical IF signals are provided by the central station allowing a very simple base station.

**Index Terms** — Frequency conversion, optical mixers, semiconductor optical amplifiers, optical modulation, millimeter wave communication, optical communication

## I. INTRODUCTION

60 GHz wireless communications are actively investigated because they have wide bandwidth, frequency reusability and high directivity. However, high transmission loss at 60 GHz and expensive 60 GHz components make it difficult to realize practical 60 GHz systems. Recently, fiber-supported 60 GHz systems are attracting much attention to solve such problems. In such systems, expensive equipment can be centralized and 60 GHz signals are delivered through fiber [1]-[5]. However, when 60 GHz signals are intensity-modulated, the resulting optical signals have two sidebands and suffer from CNR penalties due to fiber chromatic dispersion [6]. Various techniques for dispersion insensitive transmission have been proposed using single sideband filters, dispersion compensation techniques, and optical/optoelectronic frequency converters [2]-[5].

In this paper, we focus on the technique of dispersion-insensitive optical intermediate frequency (IF) transmission, where 60 GHz frequency up and down conversions are required at the base station. We demonstrate that both frequency up and down conversions are possible with a novel frequency converter based on cascaded Semiconductor Optical Amplifier (SOA) - Electro-Absorption Modulator (EAM) configuration. SOA cross-gain modulation and EAM photo-detection are used for frequency up-conversion, and EAM nonlinearity is used for frequency down-conversion. In addition, optical local oscillator (LO) and optical IF signals for bi-directional data transmission are provided by the central station. Therefore, a simple base station having one cascaded SOA-EAM can be realized. For system demonstration, downlink 10 Mbps QPSK data at 100 MHz IF is transmitted to the base station and frequency up-converted to the 60 GHz

band, and uplink 10 Mbps QPSK data in the 60 GHz band is frequency down-converted to 150 MHz IF and transmitted to the central station. By measuring Error Vector Magnitudes (EVMS), error-free bi-directional data transmission is verified. In addition, the dependence of transmission performance on power and wavelength of SOA input optical IF signals is experimentally investigated.

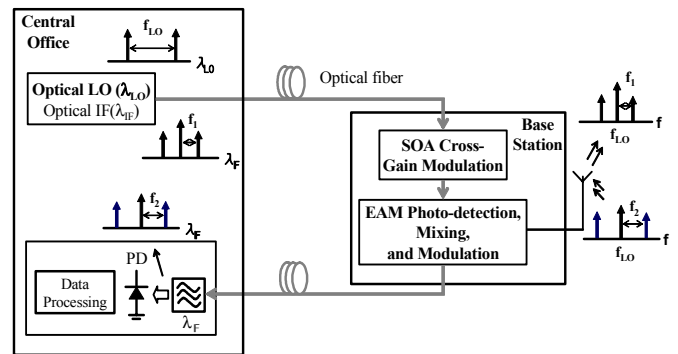

Fig. 1. Basic operation schematic using cascaded SOA-EAM for bi-directional radio-on-fiber links.

## II. OPERATION PRINCIPLES

Fig. 1 schematically shows the operation principle of frequency up/down-conversion using SOA-EAM configuration. When optical LO having two optical modes separated by  $f_{LO}$  at  $\lambda_{LO}$  and optical IF at  $\lambda_{IF}$  having two sidebands separated from the carrier by  $f_{IF}$  are transmitted from the central station and injected into the SOA in the base station, two modes of optical LO are cross-gain modulated by optical IF signals. After photo-detection in the EAM, frequency up-converted signals at  $f_{LO}$  can be obtained. This frequency up-conversion process is essentially same as in SOA-PD configuration reported in [7]. When the same EAM is modulated by the uplink signals having sidebands separated from the carrier ( $f_{LO}$ ) by  $f_2$ , frequency down-converted signals at  $f_2$  are generated optoelectronically due to EAM nonlinearity. This frequency down-converted signal at  $f_2$  modulates the optical IF signal ( $\lambda_{IF}$ ), which is then transmitted to the central station. Details of this frequency down-conversion process will be reported in [8]. The advantages of this cascaded SOA-

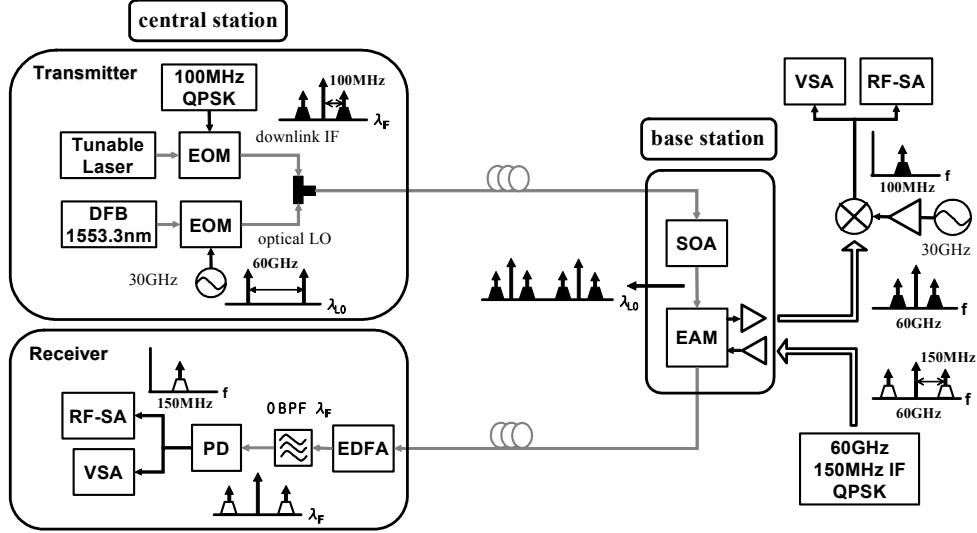

Fig. 2. Experimental setup. EOM : Electrooptic Modulator, VSA : Vector Signal Analyzer, RF-SA : RF Spectrum Analyzer, EDFA : Erbium Doped Fiber Amplifier, PD : Photo-detector.

EAM frequency converter are as follows. First, dispersion insensitive bi-directional data transmission is possible with simple base station design which does not require expensive high frequency phase-locked oscillators and mixers. Second, SOA provides conversion gain [7] which can compensate the EAM insertion loss, which is very helpful for uplink data transmission. In addition, since optical LO signals are separated from optical IF signals, optical LO can be shared among several base stations and WDM techniques can be easily used for multiplexing optical IF signals to different base stations.

### III. EXPERIMENT AND RESULTS

Fig. 2 shows the experimental setup for bi-directional data transmission. 60 GHz optical heterodyne LO signals were generated by modulating a Mach-Zehnder modulator biased at  $V_\pi$  with a 30 GHz signal. The wavelength of optical heterodyne LO signals was 1553.3 nm. For the downlink, optical IF signals were produced by modulating another MZ modulator with 10 Mbps QPSK data at 100 MHz IF. Both optical signals were combined and injected into the cascaded SOA-EAM, producing frequency up-converted signals in 60 GHz band, which was then electronically down-converted and analyzed for transmission quality. The SOA was biased at 150 mA, which gave 25 dB optical gain and 7 dBm output saturation power. The EAM was designed and packaged for 60 GHz narrow-band operation [9].

For uplink transmission, 10 Mbps QPSK data at 60 GHz were used for modulating the same EAM. These signals were mixed with optically generated 60 GHz LO signal inside the EAM and frequency down-converted. At the same time, optical IF was modulated by frequency down-converted

signals, which were then transmitted to the central station. In the central station, the uplink signal was photo-detected after optical amplification and filtering, the resulting QPSK data at 150 MHz were analyzed for transmission quality. All the results were measured at back-to-back conditions, and uplink and downlink data were modulated separately. It should be noted that 60 GHz should provide much higher bandwidth than data used in our demonstration, but our experiment was limited by available data generation and analysis instruments, not by the scheme itself.

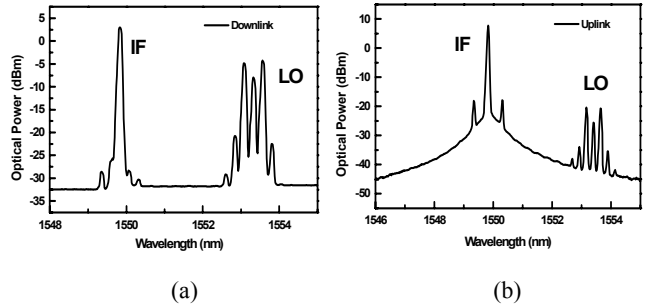

Fig. 3. Optical spectrum of downlink signals (a) and uplink signals (b).

Fig. 3 (a) and (b) show the optical spectra of the downlink and uplink signals, respectively. Fig. 3 (a) was obtained from the optical signals coming out of the SOA, and 1550 nm optical IF and 1553.3 nm optical LO can be seen. Fig. 3 (b) was obtained from the output of the optical bandpass filter (center wavelength of 1550nm) at the central station. As shown in this figure, the optical LO is suppressed about 30 dB compared with optical IF and does not affect data signals. The side peaks for optical IF in figure (a) and (b) are the results of

60 GHz signal modulation in the SOA and EAM, respectively. However, their effects on data transmission performance are negligible.

The RF spectra and EVMs of frequency converted QPSK data signals were measured. Fig. 4 (a) shows the RF spectrum of downlink frequency up-converted signals. For this measurement, -16.3 dBm optical LO and -10 dBm optical IF were injected into the SOA, and the resulting EVM was about 3.3 %, which corresponds to 29.6 dB SNR, which should be more than sufficient for many applications. Fig. 4 (b) shows the constellation and eye diagram of demodulated downlink QPSK data.

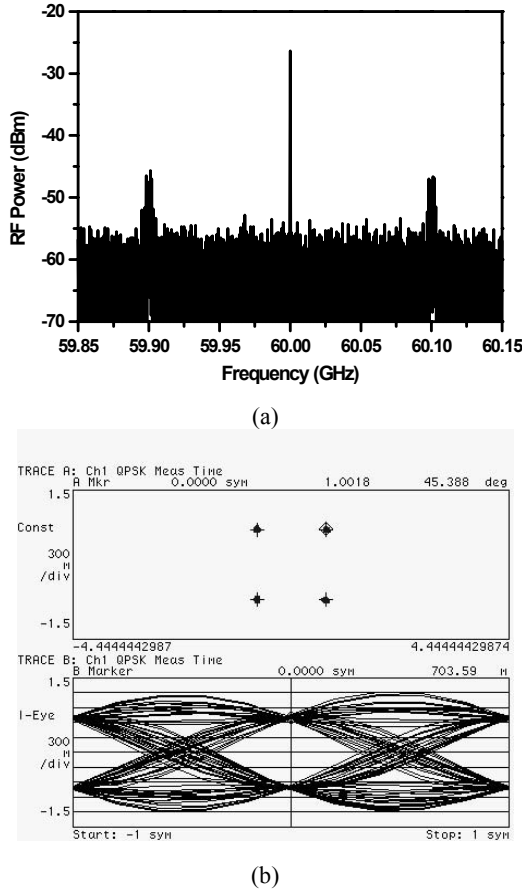

Fig. 4. (a) RF spectra of frequency up-converted downlink signals. (b) Constellation and eye diagram of demodulated QPSK data signals.

Fig. 5 (a) shows the 150 MHz RF spectrum of frequency down-converted uplink signals measured at the central station. With -15 dBm optical LO and -8 dBm optical IF signals injected into the SOA, the EVM of 7.4 % was obtained, which corresponds to 22.6 dB SNR. The constellation and eye diagram of demodulated QPSK data are shown in fig. 5 (b).

We also measured EVMs as a function of the SOA input optical IF powers for both downlink and uplink. Fig. 6 shows the measurement results. The power of optical LO was fixed at -16.3 dBm for the downlink and -15 dBm for the uplink.

The wavelength of optical IF was 1550 nm. The EAM was biased at -2.5 V for both downlink and uplink. As shown in the figure, the EVM of the downlink data transmission changes from 6 % to 3 % as SOA input optical power increases. This is simply because the low optical IF power reduces the cross-gain modulation efficiency, and the frequency up-conversion efficiency. However, when optical IF power is very high, the cross-gain modulation efficiency is saturated, so that the EVM is also saturated at around 3 %.

The EVM of the uplink data transmission also changes from 13 % to 8 % as SOA input optical power increases. In the uplink, the optical IF signal power does not seriously affect the frequency down-conversion process. However, optical IF signal is modulated by the frequency down-converted IF signals. Therefore, as the optical IF signal power increases, the power of optical IF reaching the central station increases and, consequently, the EVM decreases until it is saturated due to SOA gain saturation.

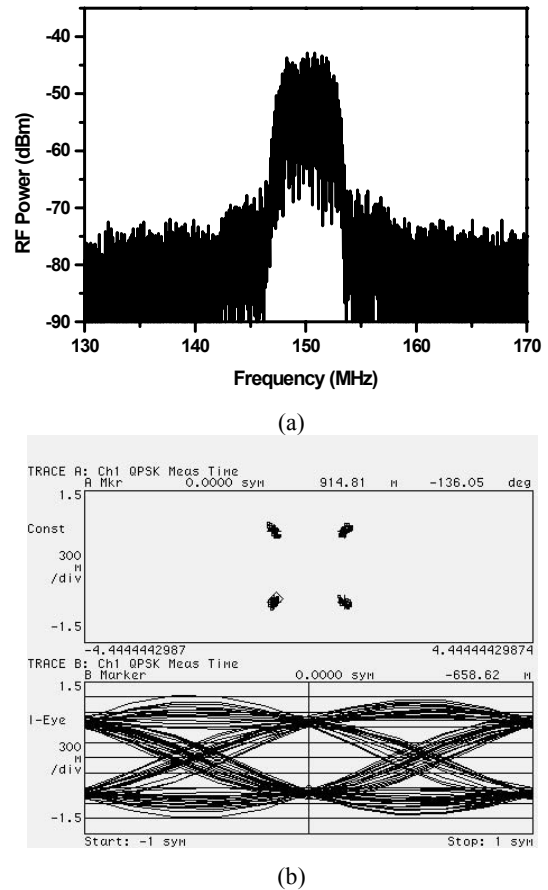

Fig. 5. RF spectrum of frequency down-converted 150 MHz uplink signals. (b) Constellation and eye diagram of demodulated QPSK data signals.

The dependence of EVM on the optical IF wavelength was also investigated in order to identify the usable IF wavelength range. The optical LO power of -16.3 dBm and -15 dBm for the downlink and the uplink was respectively used and optical

IF power was -10 dBm for the downlink and -8 dBm for the uplink. The EAM was biased at -2.5 V. Fig. 7 shows the EVM characteristics according to IF wavelength. As shown in the figure, EVMs for both downlink and uplink do not change very much. This is because the investigated wavelength is within the SOA gain and EAM modulation bandwidth, and the input optical IF power is high enough to saturate the SOA gain.

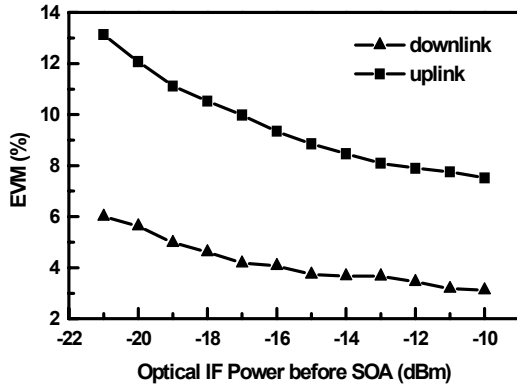

Fig. 6. Measured EVM as a function of SOA input optical IF signal power for the downlink and uplink.

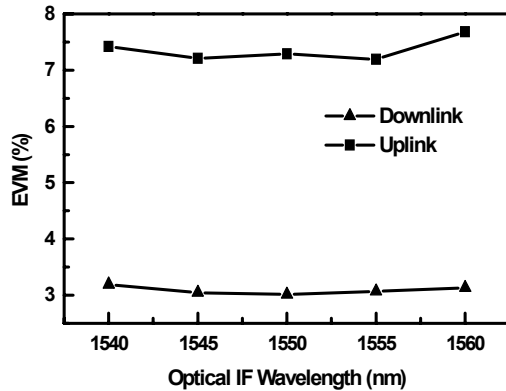

Fig. 7. Dependence of the EVM on the wavelength of optical IF signals for the downlink and uplink.

#### IV. CONCLUSION

We demonstrated a bi-directional 60 GHz radio-on-fiber system using a novel cascaded SOA-EAM configuration for frequency up/down-conversion. The advantage of this system is not only dispersion insensitive data transmission, but also realization of a very simple base station. In addition, optical LO signals can be shared among several base stations, and wavelength-separated optical IF signals allow great flexibility in system design. For downlink, 10 Mbps QPSK data at 100

MHz IF were optically transmitted to the base station and frequency up-converted to 60 GHz band. For uplink, 10 Mbps QPSK data at 150 MHz IF were frequency down-converted from 60 GHz, and after optical IF modulation, transmitted to the central station. The measured EVM confirmed high-quality transmission for both directions.

#### REFERENCE

- [1] L. Noël, D. Wake, D. G. Moodie, D. D. Marcenac, L. D. Westbrook, and D. Nessel, "Novel Technique for High-Capacity 60 GHz Fiber-Radio Transmission Systems", *IEEE Trans. Microwave Theory Tech.*, vol. 45, no. 8, pp. 1416-1423, August 1997.
- [2] T. Kuri, K. Kitayama, and Y. Takahashi, "A Single Light-Source Configuration for Full-Duplex 60-GHz-Band Radio-on-Fiber System", *IEEE Trans. Microwave Theory Tech.*, vol. 51, no. 2, February 2003.
- [3] K. Kitayama, "Ultimate Performance of Optical DSB Signal-Based Millimeter-wave Fiber-Radio System: Effect of Laser Phase Noise", *J. Lightwave Technol.*, vol. 17, no. 10, October 1999.
- [4] C.-S. Choi, H.-S. Kang, D.-H. Kim, K.-S. Seo, W.-Y. Choi, "Characteristics of InP HEMT Harmonic Optoelectronic Mixers and Their Application to 60 GHz Radio-on-Fiber Systems", *2003 IEEE MTT-S Int. Microwave Symp. Dig.*, pp. 401-404, June 2003.
- [5] T. Kuri, K. Kitayama, and Y. Ogawa, "Fiber-Optic Millimeter-Wave Uplink System Incorporating Remotely Fed 60-GHz-Band Optical Pilot Tone", *IEEE Trans. Microwave Theory Tech.*, vol. 47, no. 7, pp. 1332-1337, July 1999.
- [6] U. Gliese, S. Nørskov, and T. N. Nielsen, "Chromatic Dispersion in Fiber-Optic Microwave and Millimeter-Wave Links," *IEEE Trans. Microwave Theory Tech.*, vol. 44, no. 10, pp. 1716-1724, October 1996.
- [7] Y.-K. Seo, C.-S. Choi, and W.-Y. Choi, "All Optical Signal Up-Conversion for Radio-on-fiber Applications Using Cross-Gain Modulation in Semiconductor Optical Amplifiers", *IEEE Photon. Technol. Lett.*, vol. 14, no. 10, pp. 1448-1450, October 2002.
- [8] J.-H. Seo, C.-S. Choi, W.-Y. Choi, Y.-S. Kang, Y.-D. Jung, and J. Kim, "Remote Optoelectronic Frequency Down-conversion using 60 GHz Optical Heterodyne Signals and Electroabsorption Modulator", accepted for publication in *IEEE Photon. Technol. Lett.*
- [9] J. Lim, Y.-S. Kang, K.-S. Choi, J.-H. Lee, S.-B. Kim, and J. Kim, "Analysis and Characterization of Traveling-Wave Electrode in Electroabsorption Modulator for Radio-on-Fiber Application", *J. Lightwave Technol.*, vol. 21, no. 12, pp. 3004-3010, December 2003.